



## MACHINE SPECIFICATION

67-31-1 Effective: April 2, 2009

# BEL 290 Fully Automatic Top and Bottom Case Tape Sealer

The BEL 290 accepts uniform case sizes and automatically folds the top flaps using a safer form of top 'kicker' technology. Changes between case sizes are performed with 2 main width and height adjustments. Cases are taped top and bottom or top-only with either 2" or 3" wide tape. A BEL *Uni-Drive* conveyor system, with a single motor synchronously driving both side-belts, holds cases securely and keeps them square. The BEL 290 connects to a 120 VAC single-phase electrical outlet by a conventional cord and plug and requires compressed air at 90 psi. / 6 Bar.

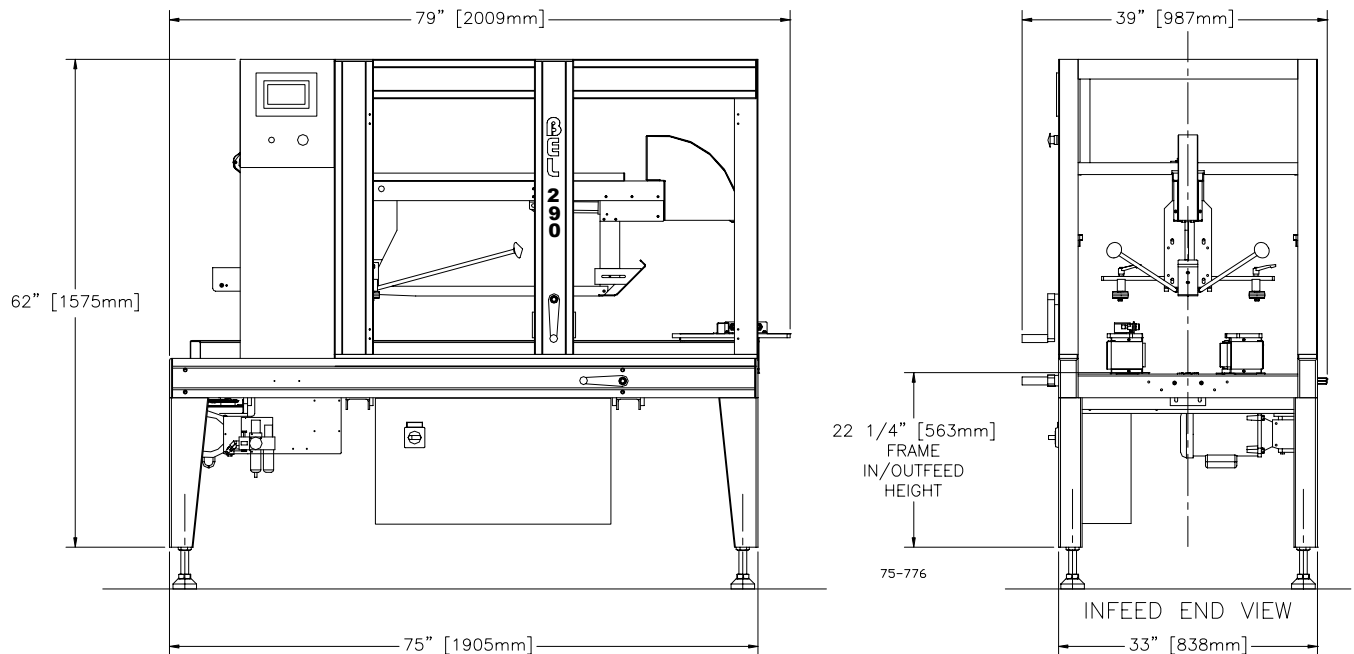

### Standard Specifications:

		<b>Length</b>	<b>Width</b>	<b>Height</b>
<b>Case Size Range</b>	Minimum	6" / 152 mm	5" / 127 mm	5" / 127 mm
	Maximum	22" / 559 mm	18" / 457 mm	19" / 483 mm
<b>Machine Dimensions</b>		79" / 2008 mm	39" / 987 mm	62" / 1575 mm
<b>In/Outfeed Height</b>	Frame	22.3" / 563 mm		
	With adjustable leg extensions [foot pad]	Minimum Maximum	24.5" / 622 mm 32" / 813 mm	
<b>Speed</b>		Up to 32 cases / min.		
<b>Shipping Weight</b>	Approx.	1,100 lbs. / 500 kg.		

For further detail, see Layout Drawing 75-776

**Construction:**

The machine frame is made of heavy-duty corrosion resistant and paint-free high tensile aluminum C-Beam extrusions, anodized after welding. Other construction materials include stainless steel, zinc plated steel and engineering plastics.

**Top Flap Folding System:**

A safer form of top rear minor flap 'kicker' uses a circle segment style of arm, specific guarding around the arm and machine enclosure guarding to avoid the major hazard with this type of folding technology.

**Controls:**

The BEL 290 has a touch screen interface display with interactive control for all normal and most optional functions. The main control uses an Allen-Bradley *MicroLogix* 1200 PLC.

**Tape Heads:**

Standard DEKKA Model 22, 2" tape width heads with quick loading feature and center-pull tape guide system. Optional DEKKA 23, 3" tape width heads and Dekka 215 / 315 shorter tape tail heads are available at extra cost.

**Conveyor Drive System:**

A *Uni-Drive* synchronized side belt conveyor system powered by a single 1/2 H.P. TEFC motor and 3/4 H.P. rated gear reducer ensures both side belt speeds are synchronized to avoid skewing of cases during transport through the sealer.

**Conveyor Belts:**

3" nominal belt size rough top continuous loop with finger splice joint, and V-rib backing.

**Electrical Specifications:**

110 -120 VAC, 10A., 60 cycle, 1-phase NEMA 12.

**Compressed Air Requirements:**

0.1 CF/Cycle @ 90 P.S.I. (6 Bar)

**Safety Provisions:**

Enclosure guarding of the top flap folding areas of the machine using interlocked doors having clear polycarbonate panels. The trailing minor flap folder 'kicker' mechanism is formed as a segment of a circle with its own close-fitting guard so there is not the exposed arm movement that has traditionally proven hazardous on the return stroke with other kicker mechanisms.

**Options:**

Case indexing stop gates, tape monitoring.

**Nameplates / Identification:**

Serial number plate

**Documentation:**

- Operation & Service Manual - providing set up, operating and troubleshooting information
- Technical Reference – spare parts kits, assembly and parts reference drawings, electrical and pneumatic schematic diagrams.

**Warranty:**

On Machinery and Parts manufactured by the Company, Wexxar Packaging Inc. (the "Company") warrants to the original purchaser ("Buyer") of the product described above (the "Product") that:

- (a) all non-moving, structural components of the Product (excluding hot melt systems and tapeheads) in all material respects, will be free of defects due to imperfect material or workmanship for a period of One (1) year from the date of invoice:
- (b) all powered mechanical parts of the Product, in all material respects, will be free of defects due to imperfect material or workmanship for a period of at least one (1) year from the time of shipping from the Company's factory;

and following Company's acceptance of a warranty claim, upon the Buyer's delivery of the defective Product to the Company's factory, the Company will repair or replace it at the Company's option.

The warranties set out above do not extend or apply to:

- (a) the routine replacement of parts due to normal wear and tear arising from use; this warranty does not extend to parts which may presumably be expected to wear out during the warranty period;
- (b) damage attributable to accident, misuse, improper maintenance, power surge, improper connection to a power source, placement of Product in hostile environment, or alterations not authorized by the Company, negligence, or accident;
- (c) accessories, attachments, parts or instruments sold with or attached to the Product that do not bear the Company's trade mark ("Components");
- (d) any warranty claim not made in writing to the Company at its head office within the applicable warranty period and within ten (10) days of Product failure.
- (e) This warranty does not cover shipping costs;

This warranty shall be the only warranty in effect and is made exclusive of all other warranties and guaranties written or oral, expressed or implied.

**COMPONENTS**

On request and to the fullest possible extent, the Company will assign to the Buyer any interest it has in Component suppliers' warranties for separately manufactured parts and accessories which form; are attached to; or constitute part of the Product. This includes tape heads.

**CANCELLATION**

Orders cannot be cancelled without consent of an authorized employee of the Company and in such cases the customer will fully indemnify the Company, unless agreed otherwise in writing by the Company.

**TITLE**

The title and right of possession of the goods quoted hereto shall remain with the Company and such goods shall remain Company property until all payments have been made in full. The purchaser agrees to do all that is required to maintain such right and title with the Company.

**PRICE**

All prices quoted are F.O.B. Company warehouse unless otherwise specified. Prices quoted are subject to change and do not include taxes or duties, if applicable.